

**Bergerault Signature
Marimba**

5 OCT C To C
GMBH
KM-SRS50S

Signature Marimba

Index	1	2	3	4	5
Designation	Frame	Central Bar and Damper	Rails	Resonators Tubes	Bars
Quantities	2	1	4	2	2
Sketch	<p>Large side frame Red dot on central hub</p> <input type="checkbox"/> <p>Small side frame</p> <input type="checkbox"/>	<p>Central bar</p> <input type="checkbox"/>		<p>Résonator Accidental tubes</p> <input type="checkbox"/> <p>Résonator Natural tubes</p> <input type="checkbox"/>	<p>Accidental bars</p> <input type="checkbox"/> <p>Natural bars</p> <input type="checkbox"/> <p>Cover</p> <input type="checkbox"/>

Step 1: Connect the end pieces together with the central metal bar

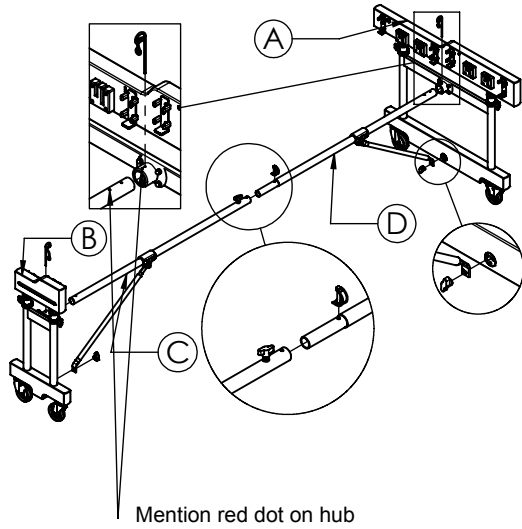

Step 2: Connect the front rail

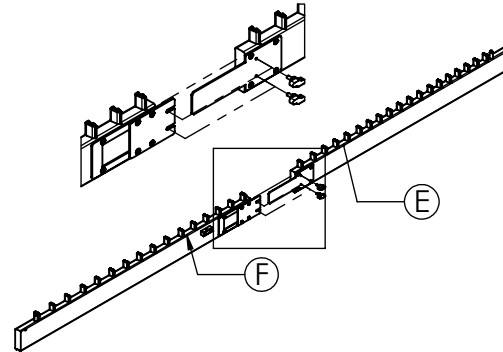

Step 3: put the two central rails on the holders

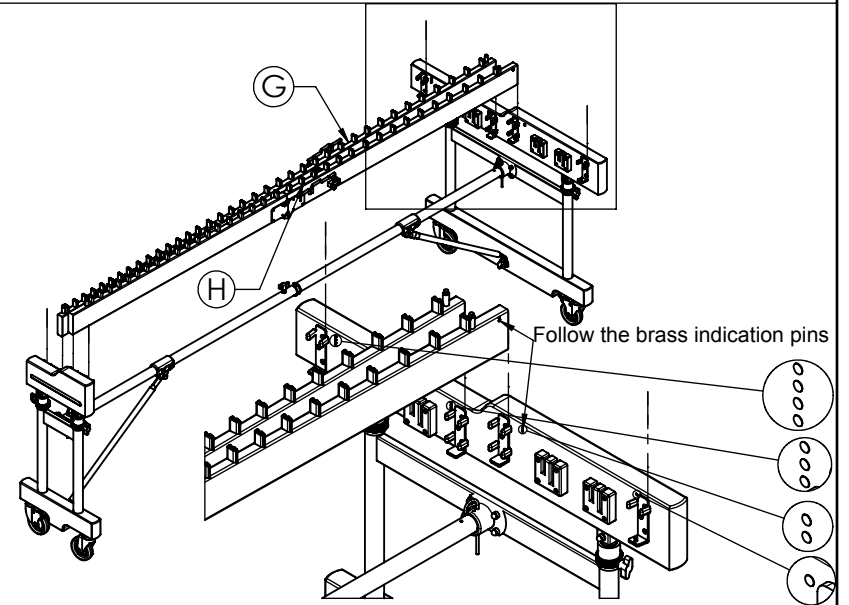

Step 4: Place the resonator tubes on the frame

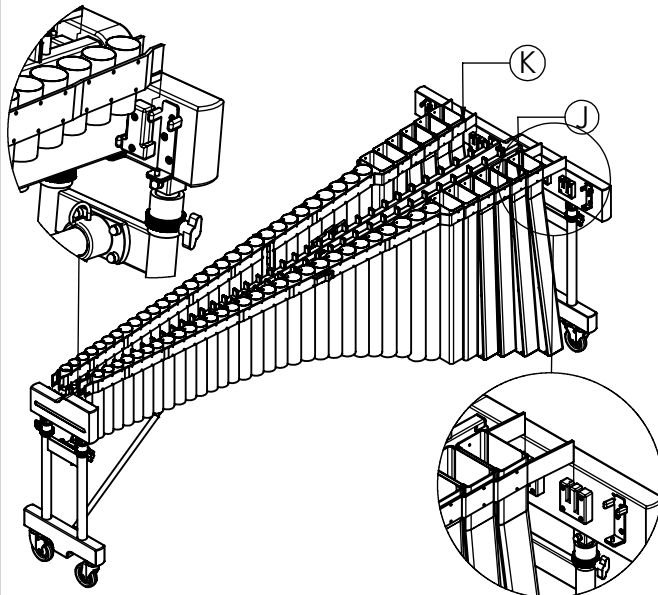

Step 5: Put the frontside and backside rails

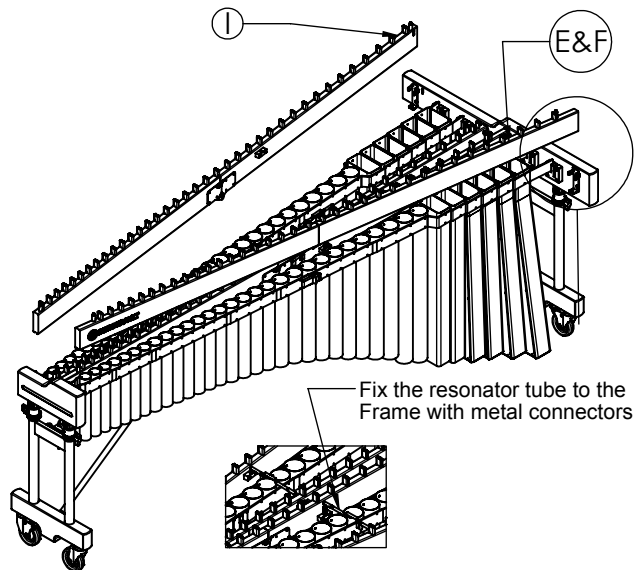

Step 7: put on the keys

