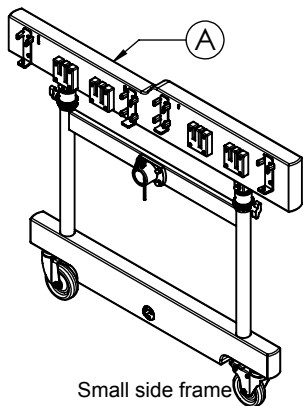
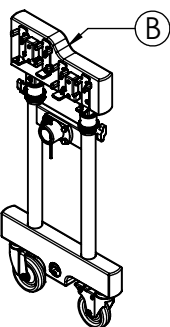
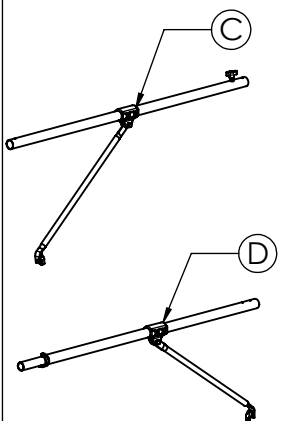
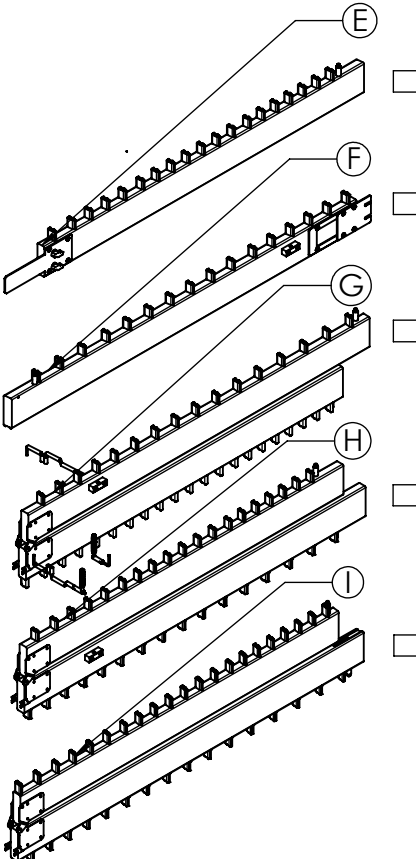
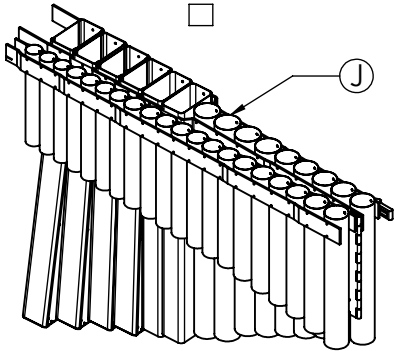
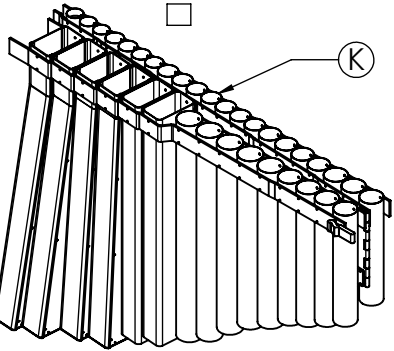
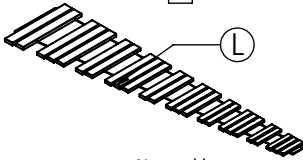
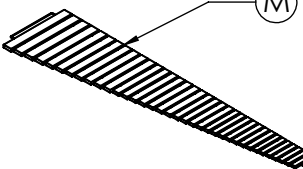
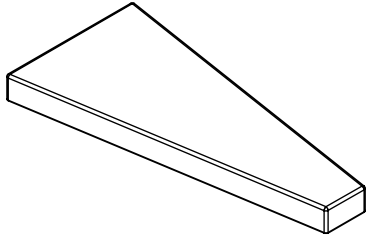

**Bergerault Signature  
Marimba**

5 OCT C To C  
GMBH  
KM-SRS50S

**Signature Marimba**

Index	1	2	3	4	5
Designation	Frame	Central Bar and Damper	Rails	Resonators Tubes	Bars
Quantities	2	1	4	2	2
Sketch	<p>Large side frame Red dot on central hub</p> <input type="checkbox"/>  <p>Small side frame</p> <input type="checkbox"/> 	<p>Central bar</p> <input type="checkbox"/> 		<p>Résonator Accidental tubes</p> <input type="checkbox"/>  <p>Résonator Natural tubes</p> <input type="checkbox"/> 	<p>Accidental bars</p> <input type="checkbox"/>  <p>Natural bars</p> <input type="checkbox"/>  <p>Cover</p> <input type="checkbox"/> 

**Step 1: Connect the end pieces together with the central metal bar**

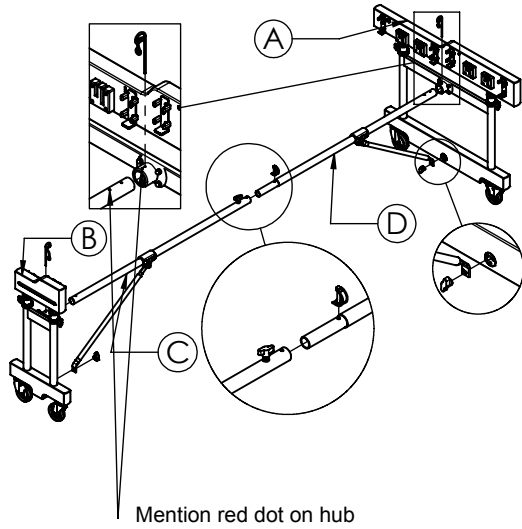

**Step 2: Connect the front rail**

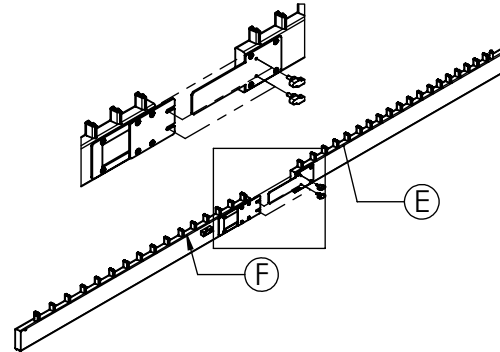

**Step 3: put the two central rails on the holders**

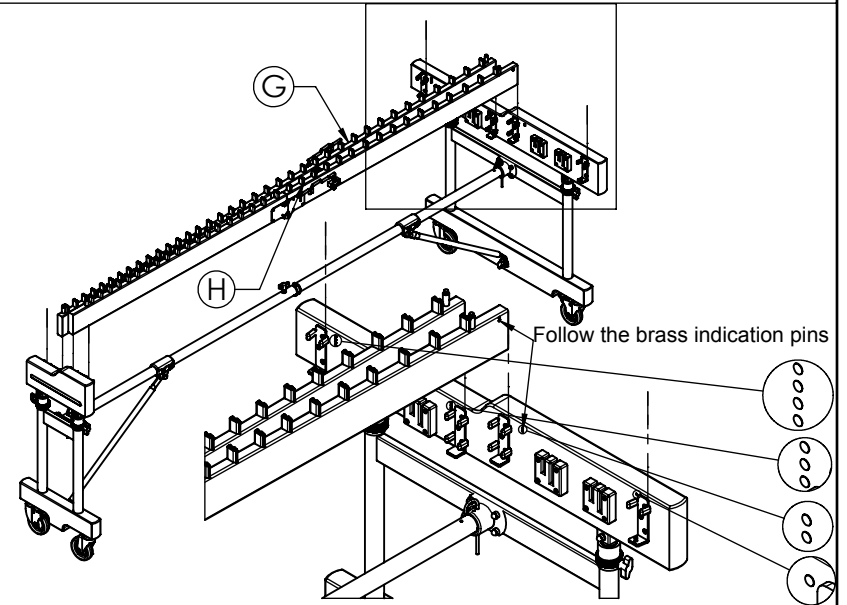

**Step 4: Place the resonator tubes on the frame**

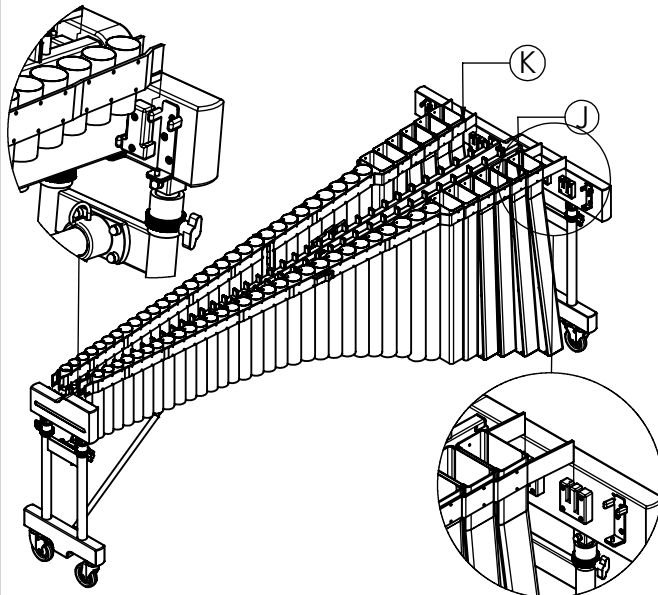

**Step 5: Put the frontside and backside rails**

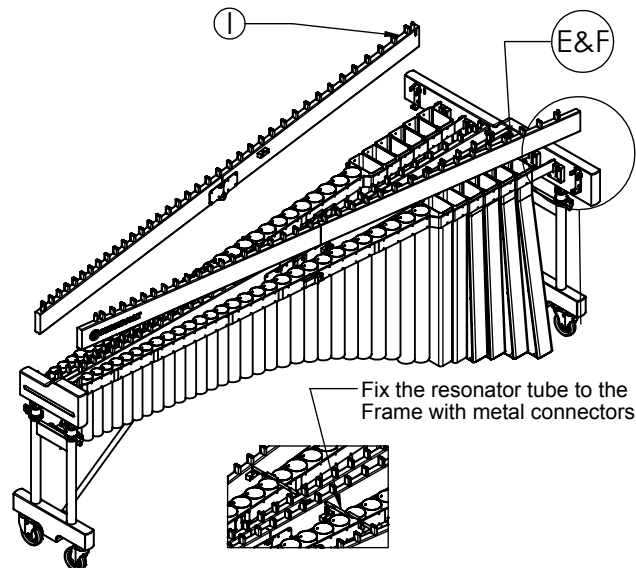

**Step 7: put on the keys**

